

# 1963 Corvette: Service Bulletin: Revised 1963 Corvette Rear Wheel Spindle

**Subject:** Revised 1963 Corvette Rear Wheel Spindle

**Model and Year:** 1963 Corvette

**Source:** Chevrolet Technical Service Bulletin

**Bulletin No:** DR #599

**Section:** IV

**Date:** June 10, 1963

TO: ALL CHEVROLET DEALERS

Excessive rear wheel spindle and spindle bearing wear on 1963 Corvettes may be a result of the bearing inner races rotating on the spindle.

Design improvements to the spindle and spindle flange assemblies have produced two interim production changes to eliminate this wear problem. A review of spindle design is outlined on Page 2.

These design changes have also resulted in revised service procedures and a deletion of the 30,000 mile service interval. The new spindle assembly requires no periodic servicing.

Where complaints of spindle wear are encountered on vehicles built before December 3, 1962, the problem may be corrected by replacing the original design or interim change spindle and flange with the new Part No. 3840378 spindle, Part No. 3839830 drive flange and Part no. 3839832 flange washer. Service instructions on the following pages outline the recommended service

procedures and tools.

### SPINDLE DESIGN CHANGES

A - From initial production to November 2, 1962, spindle 3817724 incorporated slip fit inner and outer bearing diameters and was assembled with 50 lb. - ft. drive flange nut torque (Figure 1).

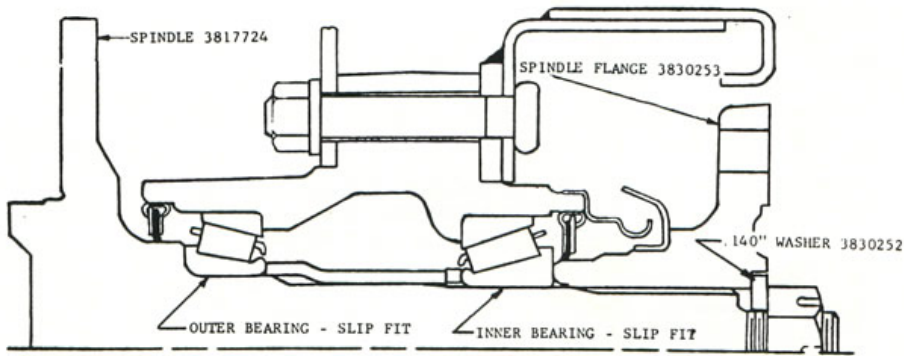

FIGURE 1

B - From November 2, 1962, to November 19, 1962 production, spindle 3817724 was revised to incorporate an interference fit outer bearing diameter and a .0005" loose to .0005" tight inner bearing diameter. A chamfer was added to the outer bearing shoulder to provide for tool access (Figure 2).

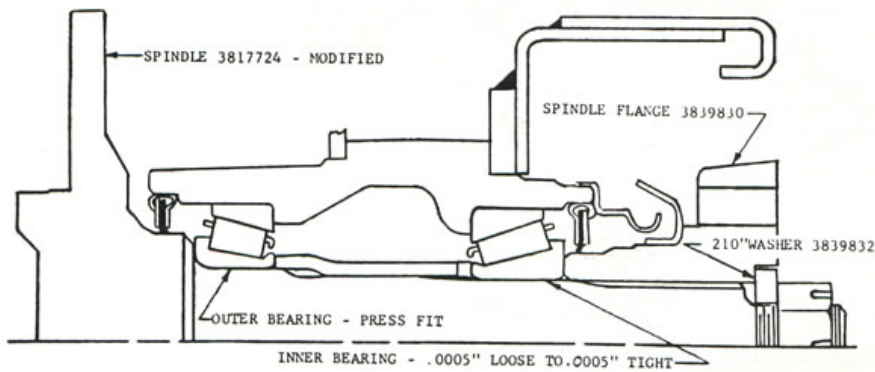
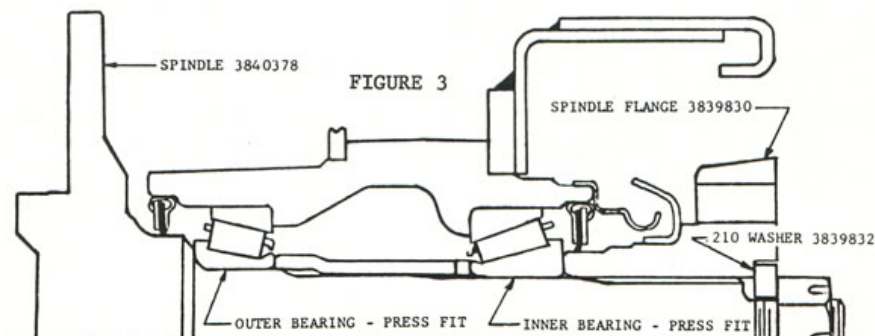

FIGURE 2

C - Beginning with November 19, 1962 production, a .210" thick spindle flange washer 3839832 replaced with .140" thick spindle flange washer 3830252, and a new flange assembly 3839830 replaced the old flange assembly 3830253. Drive flange nut torque increased from 50 lb. - ft. to 100 lb. - ft. (Figure 2).

D - Beginning with December 3, 1962 production, a new design spindle 3840378 replaced spindle 3817724. The new spindle incorporates interference fit inner and outer bearing diameters. This new spindle is used in conjunction with drive flange 3839830 and washer 3839832, and is assembled with 100 lb. - ft. drive flange nut torque (Figure 3).



## SERVICE INSTRUCTIONS

### REAR WHEEL SPINDLE - DESIGN B AND C - FIGURE 2

1. Remove axle drive shaft, spindle drive flange nut, washer and drive flange.
2. Install puller J-8433 with puller legs located vertically on torque control arm and puller screw centered on spindle inner end. Press spindle out of support by turning puller screw.
3. If new outer bearing is needed, discard spindle and outer bearing assembly. Pry out dust shield and inner seal; remove inner bearing and discard.
4. Bearing cups may be removed from support by inserting remover tools shown in the 1963 Corvette Shop Manual Section 4, Figure 8, and tapping cups out.
5. Install new inner and outer bearing cups using J-7817 cup installer.
6. Press new outer bearing on new spindle 3840378 using J-5590 bearing installer. Support spindle on J-5746 axle shaft bearing installer to provide clearance between spindle wheel studs and press bed. Note - Insert new outer seal on spindle before installing bearing.
7. Replace inner seal and dust shield. Insert spindle into support until interference is felt. Tap outer seal into support.
8. Measure drive flange washer thickness. If washer is .140" thick, discard washer and drive flange and replace with .210" washer 3839832 and new drive flange 3834830.
9. Place J-4731 sleeve tool and spindle washer over end of spindle. Draw spindle in place with spindle nut. Remove nut, washer and J-4731. Install drive flange, washer and nut. Torque to 100 lb. - ft. and install cotter pin.

### REAR WHEEL SPINDLE - DESIGN D - FIGURE 3

#### Wheel Bearing Adjustment

Wheel bearing end play inspection may be made as outlined in the 1963 Corvette Shop Manual, Page 4-3. Refer also to the 1963 Corvette Shop Manual, Section 4, for all service procedures except those revised steps listed below. For each revision, reference is made to the original step as shown in the Manual.

Step 3, Page 4-4 - Install puller J-8433 with puller with legs located vertically on torque control arm and puller screw centered on spindle inner end. Press spindle out of support by turning puller screw.

Step 4, Page 4-4 - Pry out inner seal and remove inner bearing, shim and bearing spacer.

Step 6, Page 4-4 - a) After determining shim thickness, install inner bearing into support and tap new seal into position. b) Place bearing spacer and shim on spindle and insert spindle into support until interference is encountered. Place J-4731 sleeve tool and spindle washer over end of spindle. Draw spindle in place with spindle nut. Remove nut, washer and J-4731. Tap outer seal into support. Install drive flange, washer and nut. Torque nut to 100 lb. - ft. and install cotter pin. c) Torque spindle nut to 100 lb. - ft. plus additional amount necessary to line up cotter pin holes. Check spindle for free rotation.

Measure end play as outlined in the 1963 Corvette Shop Manual under Inspection, Page 4-3.

## Service Operations

Removal - Remove and disassemble spindle assembly as outlined in Steps 3 and 4 above.

## Repairs

Step 2, Page 4-4 - Bearing cups may be removed while spindle support is still mounted to the torque arm by inserting remover tools and tapping cup out. New inner and outer bearing cups are installed using J-7817 cup installer with drive handle J-8092.

Step 3c, Page 4-4 - Spindle support may be removed and both bearing cups serviced by using J-7817 cup installer and handle J-8092.

## Assembly

Step 1, Page 4-4 - If original wheel bearing assemblies are reinstalled, pack inner bearing and place into spindle support in original position.

Step 2, Page 4-4 - Tap new inboard seal into support until firmly seated and install dust shield.

Step 4, Page 4-4 - Pack outer bearing and assemble spindle assembly and components as outlined in Wheel Bearing Adjustment.

Step 4a - If new wheel bearings are installed, remove outer bearing race and roller assembly from spindle by placing J-8331 press plates between bearing inner race and bearing seat on spindle. Force press plates shut in a vise until the wedging action lifts the bearing from its seat. Then remove bearing in a normal manner in an arbor press with J-8331 press plates in holder J-358-1.

Step 4b - Remove outer seal and replace with new seal, if damaged. New outer seal must be placed on spindle before the outer bearing race and roller assembly is installed on spindle.

Step 4c - Press new outer bearing race and roller assembly on spindle using J-5590 bearing installer. Support spindle on J-5746 axle shaft bearing installer to provide clearance between spindle wheel studs and press bed.

Step 4d - Install new bearing cups into spindle support.

Step 5, Page 4-4 - Determine correct shim thickness as follows:

Step 5a - Install new inner bearing race and roller assembly into position. Tap in inner seal and install dust shield. Assemble bearing spacer and a .145" shim on spindle. Insert this assembly into spindle support through inner bearing. Place J-4731 sleeve tool and spindle washer over end of spindle. Draw spindle in place with spindle nut. Remove nut, washer and J-4731. Install drive flange, washer and nut. Torque nut to 100 lb. - ft. and install cotter pin.

Step 6, Page 4-4 - Assemble spindle support assembly as outlined in revised Steps 1 - 4 in Wheel Spindle Support Assembly.

## PARTS DATA - CURRENT DESIGN

<u>Part No.</u>	<u>No. Required</u>	<u>Description</u>
3840378	1	Rear Wheel Drive Spindle
3839830	1	Rear Wheel Spindle Drive Flange
3839832	1	Rear Wheel Spindle Drive Flange Washer

## FLAT RATE

<u>Time</u>	<u>Description</u>
2.0 hrs.	Spindle Bearings and/or Oil Seals Replace - One side

Online URL:

<https://www.corvetteactioncenter.com/tech/knowledgebase/article/1963-corvette-service-bulletin-revised-1963-corvette-rear-wheel-spindle-1035.html>