

# 1984 - 1987 Corvette: Chevrolet Central Office Letter to Corvette Owners: Roof Panel Damage

**Subject:** Roof Panel Damage

**Model and Year:** 1984 - 1987 Corvette

**Source:** Chevrolet Central Office Letter to Corvette Owners

**Page Number:** NA

**Date:** April 1988

Dear Chevrolet Corvette Owner:

It has been brought to our attention that a small number of 1984 - early 1987 model year Chevrolet Corvette owners may have experienced a condition whereby the removable acrylic roof panel can accidentally be damaged.

Attempting to lift the front edge of the top excessively while it is seated in the rear compartment stowage brackets, without sliding the top out of the brackets (as could possibly occur when attempting to stow items underneath the top), can lead to the top binding on the bracket covers. Forcing the top beyond this point may damage or crack the rear corners of the top resulting in a repair expense on the part of the owner which is not reimbursable.

Corvettes owners constitute a unique and very special group of Chevrolet customers. With this in mind, and in keeping with our commitment to customer satisfaction, Chevrolet is sending you new removable top stowage bracket covers for installation on your Corvette. These bracket covers allow for additional pivotal movement and will help ensure that no accidental damage occurs to your top. You can easily install the new bracket covers with only a Phillips screw driver by the following the enclosed set of instructions.

Chevrolet Motor Division is taking this action in the interest of your continued satisfaction with your Corvette.

Chevrolet Motor Division  
GENERAL MOTORS CORPORATION

## INSTALLATION INSTRUCTIONS

TOOL REQUIRED - MEDIUM PHILLIPS SCEWDRIER

### 1985-1987 MODELS

1. RAISE HATCH GLASS WINDOW.
2. REMOVE THE TWO SCREWS FROM EACH COVER (SCREWS WILL BE REUSED).
3. REMOVE THE ORIGINAL COVERS.
4. INSTALL THE NEW COVERS AND TIGHTEN THE TWO SCREWS

### 1984 MODELS ONLY

1. FOLLOW STEPS 1-3 ABOVE
2. INSTALL ONE OF THE SCREWS THROUGH THE INBOARD SCREW HOLE IN ONE OF THE NEW COVERS (SEE ILLUSTRATION).
3. PLACE A NUT-SPACER WITH THE WASHER SIDE TOWARD THE COVER ON THE PREVIOUSLY INSTALLED SCREW.
4. PLACE THE COVER BACK ON THE BRACKET, BEING CAREFUL NOT TO SHARE THE NUT-SPACER OFF THE SCREW. NOTE: THIS NUT-SPACER IS REQUIRED TO SUBSTITUTE FOR THE MOLDED IN FIN-SPACERS WHICH WERE ONLY ON THE 1984 COVERS.
5. RE-INSTALL THE SECOND SCREW AND TIGHTEN BOTH SCREWS, BEING CAREFUL NOT TO TIGHTEN THE SCREWS TO THE POINT OF DEFORMING THE COVER.

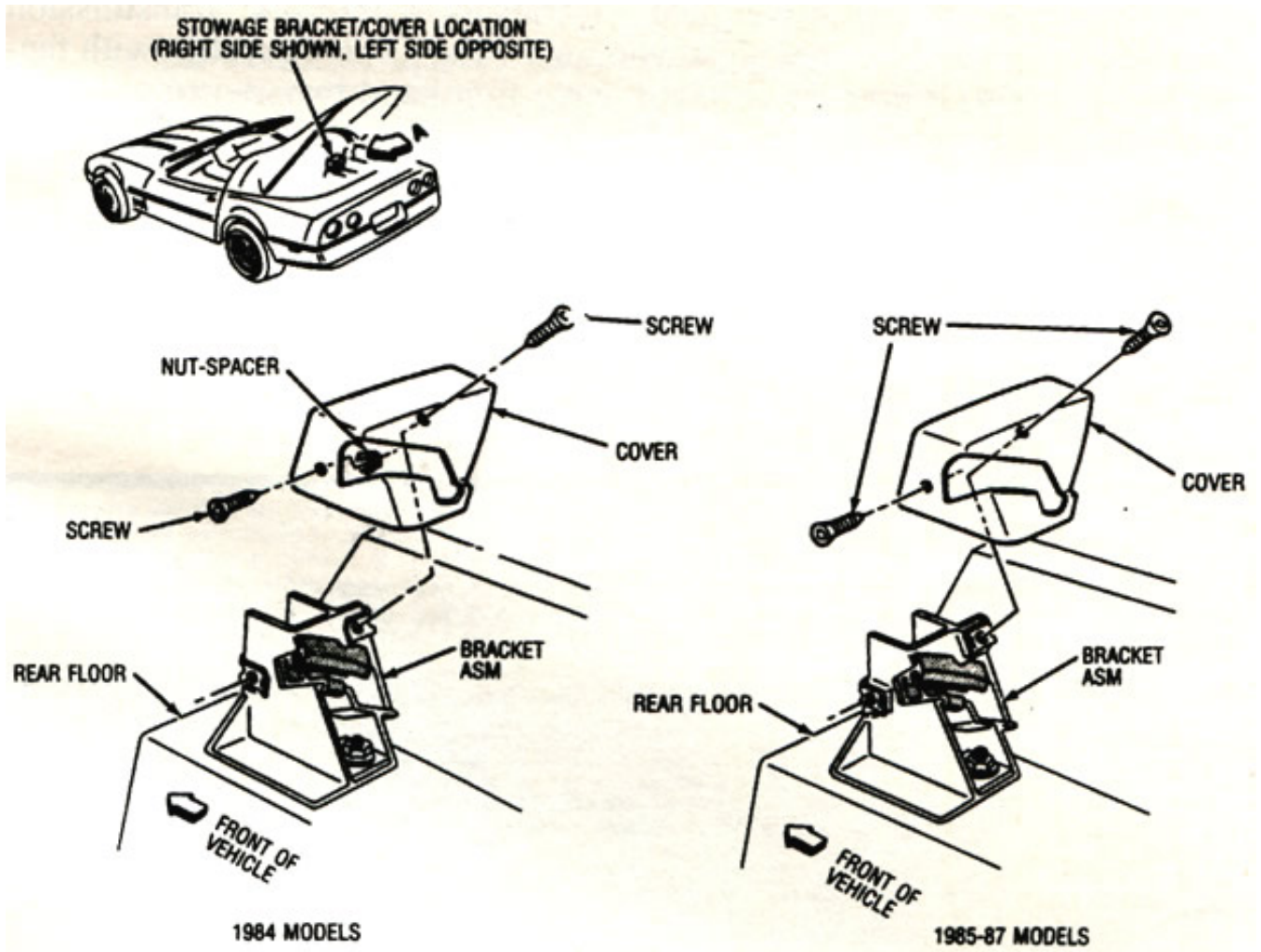

Online URL:

<https://www.corvetteactioncenter.com/tech/knowledgebase/article/1984-1987-corvette-chevrolet-central-office-letter-to-corvette-owners-roof-panel-damage-1075.html>