

# 1968 Corvette: Chevrolet Engineering Memo: Window Service Update

**Subject:** Window Service Update  
**Model and Year:** 1968 Corvette  
**Source:** Chevrolet Engineering Memo - Mr. G. H. Tyler of Chevrolet Engineering  
**Page Number:** NA  
**Date:** March 1968

## UPC I - BODY

MISC . Information from Mr. G. H. Tyler of Chevrolet Engineering

The adjustment procedure for 1968 Corvette door window glass has been revised as of this date. Items No. 3 and 4 have been revised.

### GLASS ADJUSTMENT PROCEDURE

1. Loosen bolts (A) and adjust the fore and aft tilt of the door window glass by rotating until a constant gap, or relationship, is obtained between the front edge of glass and the windshield pillar. Retighten bolts (A).
2. Loosen the front and rear stop screws (B) and roll glass up until top edge is .46 below roof rail. Move front and rear stops to contact the window rollers. Retighten screws (B).
3. Loosen the 3 bolts (C) and front nut (F) and slide door glass forward so that the front edge is .44 from and parallel to the windshield pillar. Retighten bolts (C).
4. Loosen bolts (D), (E) and rear nut (F). move bailey weatherstrip outboard so outer nylon pads are in contact with door outer panel reinforcement. Retighten bolts (E). move glass run channel so the top

of the glass is .58 from the vertical flange of the roof rail (move the glass run channel outboard to move the upper edge of glass inboard, move the glass run channel inboard to move the upper edge of glass outboard.) Retighten bolts (D).

5. Turn adjusting screw (G) so the front and rear inner nylon pads are in light contact with the wedges. Tighten nuts (F).
6. Loosen screw (H) and roll glass down until top edge is flush with door outer panel. Move stop to contact the window roller. Retighten screw (H).
7. Install and adjust windshield pillar weatherstrip, front rail weatherstrip, center rail weatherstrip, and rear rail weatherstrip to seal on glass.

Above procedure pertains to Assembly Plant operation. For Service, remove weatherstrip, weatherstrip retainer and door trim panel prior to glass adjustment.

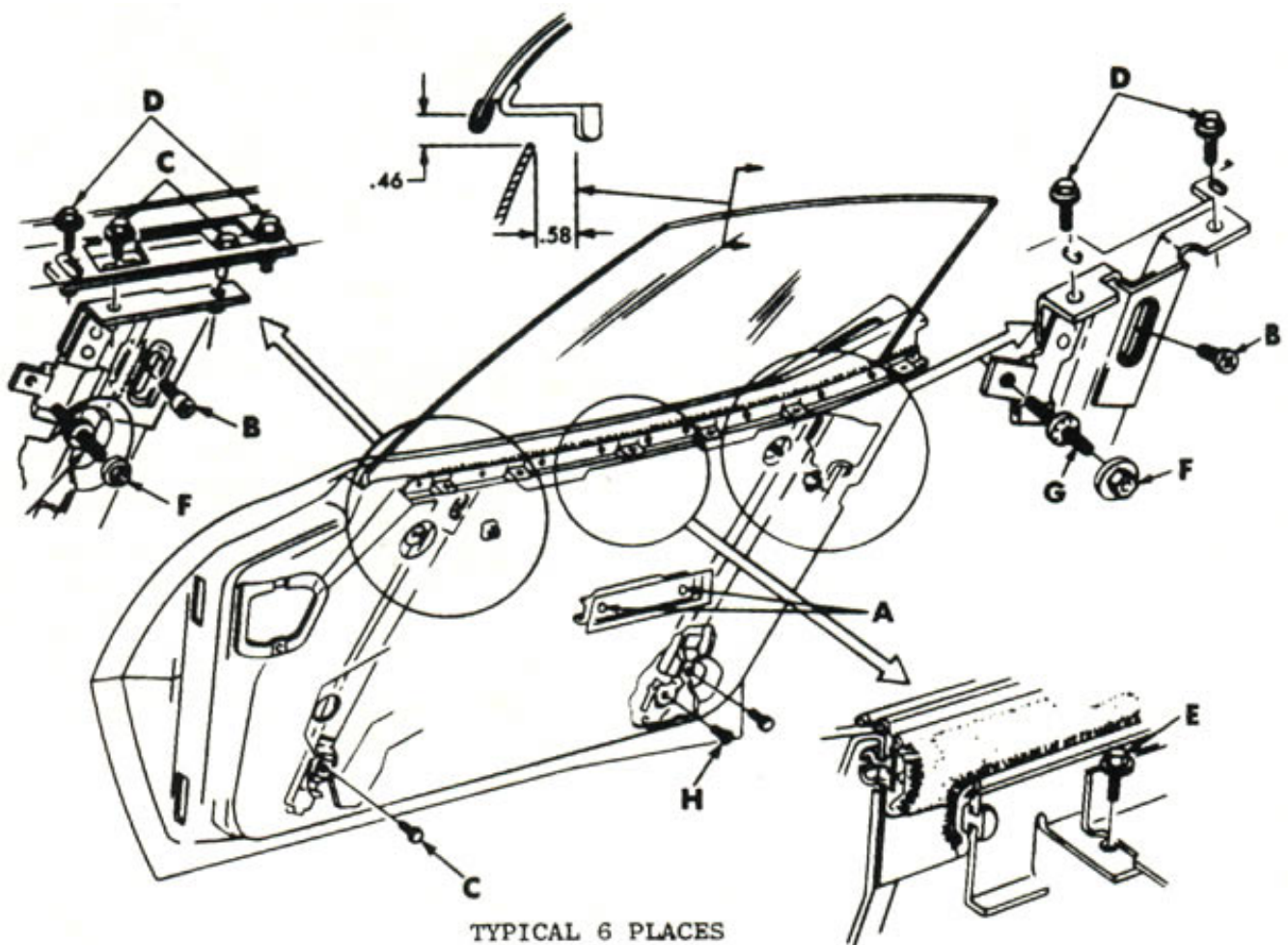

Online URL:

<https://www.corvetteactioncenter.com/tech/knowledgebase/article/1968-corvette-chevrolet-engineering-memo-window-service-update-1227.html>