

# C7 Corvette: Service Information: Transmission Control Lever Knob Replacement

## C7 Corvette Transmission Control Lever Knob Replacement

### Removal Procedure

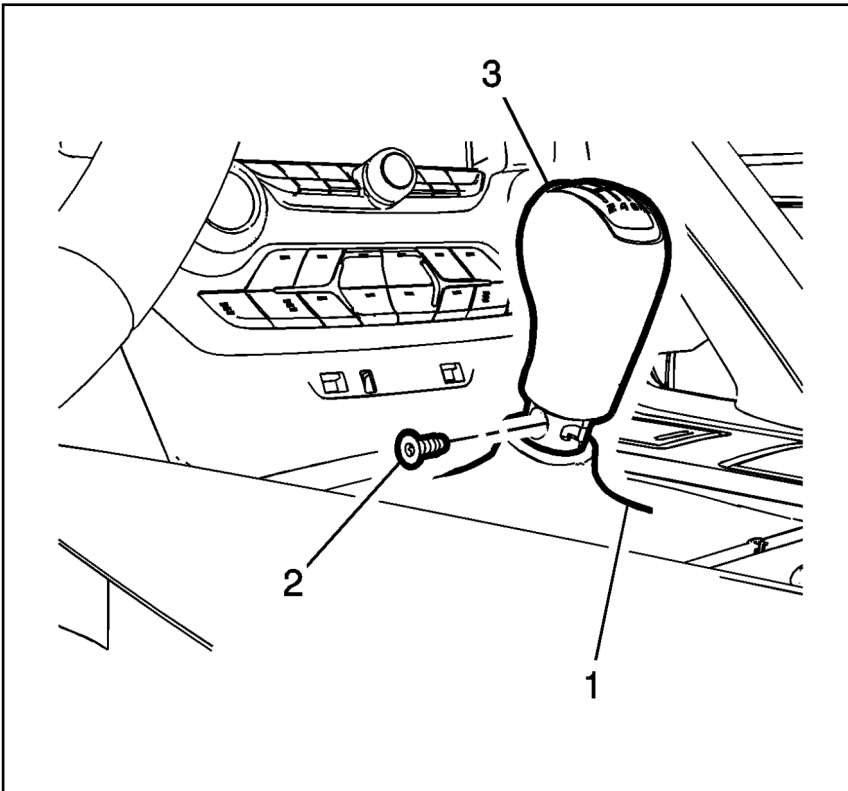

1. Carefully remove the shift control knob trim ring (1) by lifting upward and turning 1/4 turn counter-clockwise and pulling downward.
2. Remove the shift control knob retaining fastener (2).
3. Remove the shift control knob (3).

### Installation Procedure

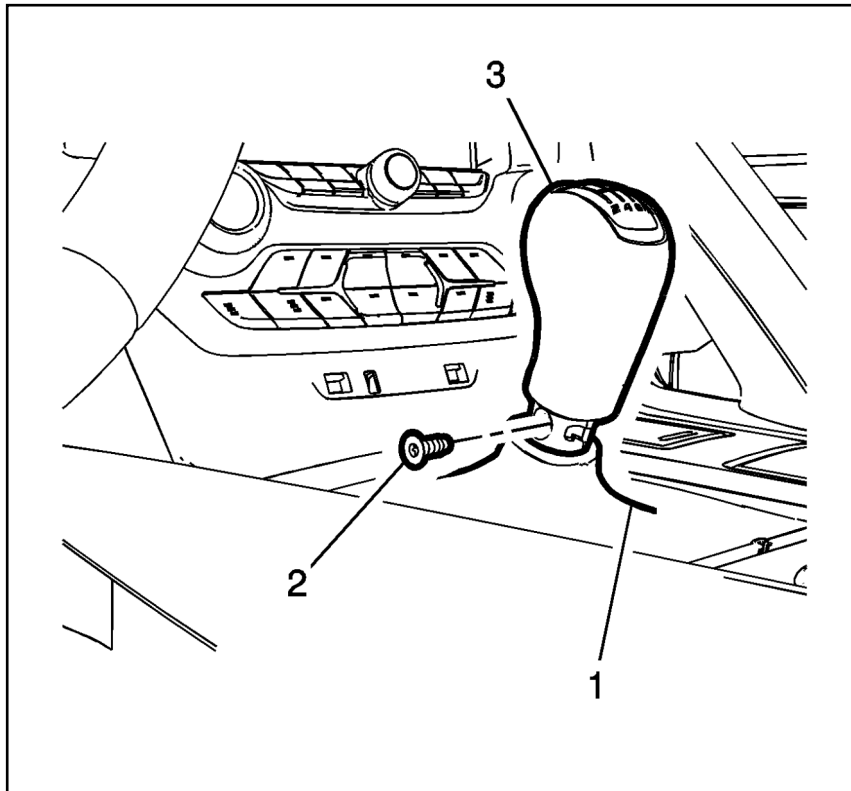

1. Clean the stub shaft and fastener (2) threads prior to reinstalling the shift knob to remove residual threadlocker using a (recommended) tap and die set.
2. Install the shift control knob (3) onto the shift control lever.
3. Apply threadlocker to the shift knob fastener (2) and install the fastener.

**Caution:** Refer to **Fastener Caution** .

1. Install the shift control knob retainer fastener (2) and tighten to **7 Y (62 lb in)** .
2. Install the shift control knob trim ring (1) and turn clockwise to lock into place.

Online URL:

<https://www.corvetteactioncenter.com/tech/knowledgebase/article/c7-corvette-service-information-transmission-control-lever-knob-replacement-1294.html>