

2014 - 2016 Corvette: Service Bulletin: #PI1116A: Door Rattle Noise from Outside of Vehicle During High Radio Volume or High Bass Levels - (Sep 14, 2016)

#PI1116A: Door Rattle Noise from Outside of Vehicle During High Radio Volume or High Bass Levels - (Sep 14, 2016)

Subject:	Door Rattle Noise from Outside of Vehicle During High Radio Volume or High Bass Levels
Models:	2014-2016 Chevrolet Corvette
Attention:	This PI also applies to any of the above models that may be Export from North America vehicles.

This PI has been revised to remove a breakpoint and add the 2015-2016 Model Years. Please discard PI1116.

Condition/Concern

Some customers may comment on hearing a driver or passenger front side door rattle noise during high radio volume or high bass levels. The noise is most commonly described as more evident from outside the vehicle rather than inside.

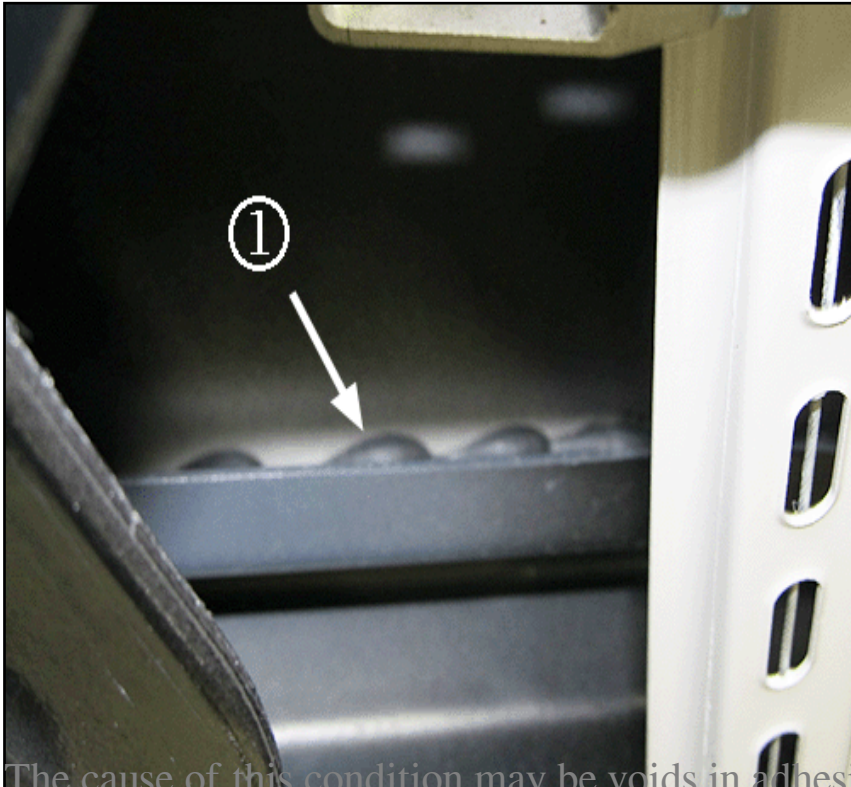

The cause of this condition may be voids in adhesive (1), leaving gaps between the inner door beam and the door skin.

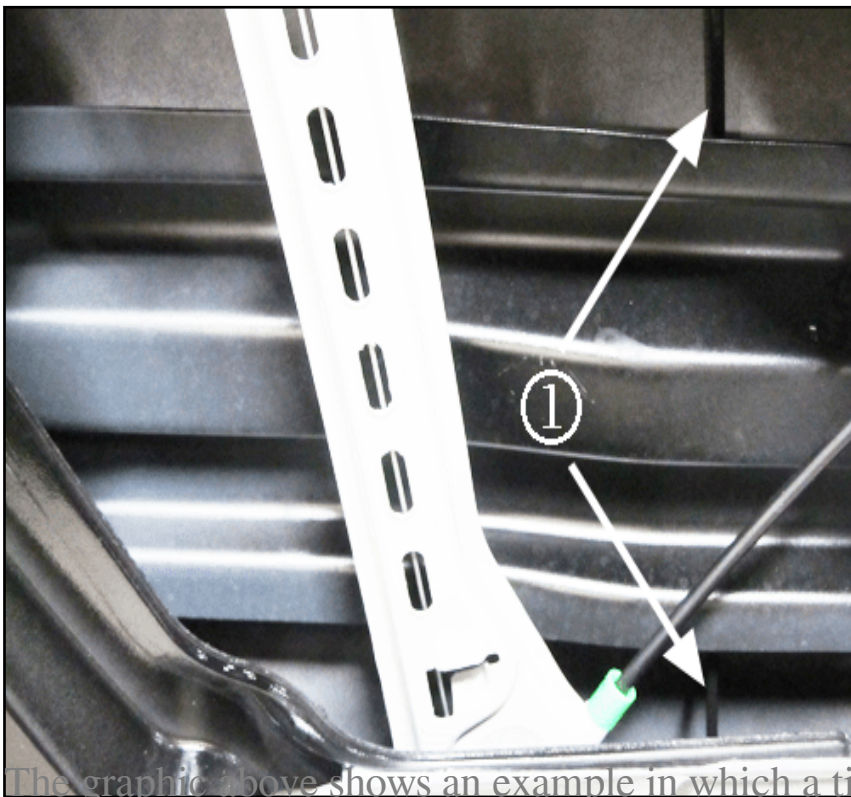

The graphic above shows an example in which a tie strap (1) was passed through a 15-20 cm (6-8 in) length gap where the adhesive was missing towards the center of the door.



This can also occur in the front and/or rear area of the door beam; with the condition sometimes more evident in the front area (shown above) where the radio speaker is mounted.

Recommendation/Instructions

Inspect the front side door beam and door skin gap for voids and add a bead of butyl ribbon sealer in those areas following the steps below:

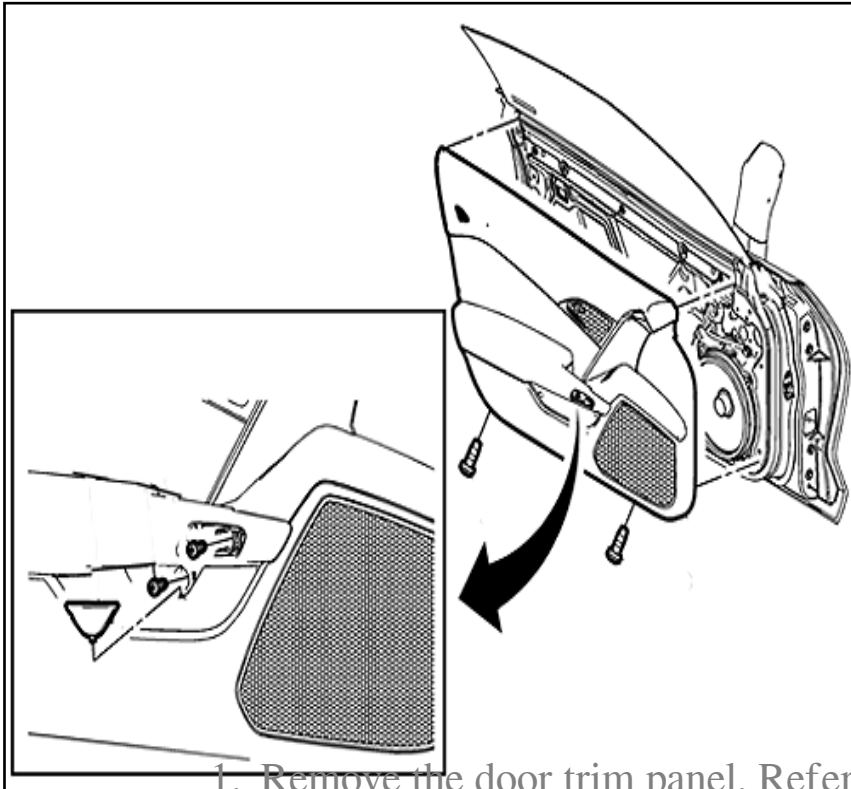

1. Remove the door trim panel. Refer to *Front Side Door Trim Replacement* in SI.

2. Peel down the door water deflector enough to access

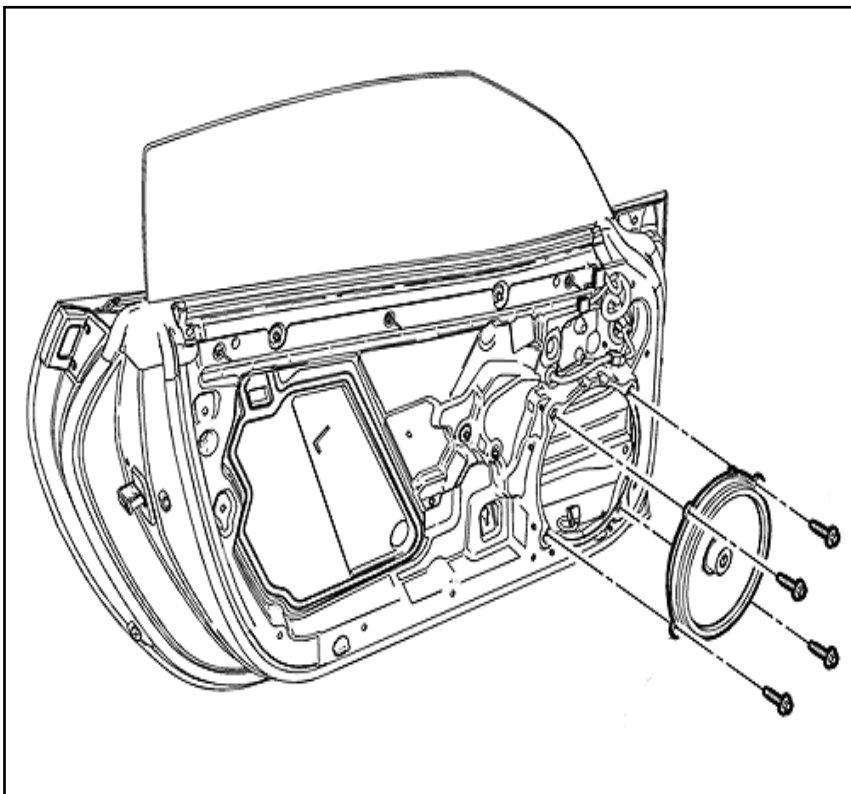

1. Remove the front door lower speaker. Refer to *Radio*

Front Side Door Speaker Replacement in SI.

2. Inspect the gap between the inner door beam and door



Tip: Use of a trim stick, or equivalent tool, may help to work the sealer into the gap.

1. Add a bead of *3M Windo-Weld™ Ribbon Sealer P/N 08611, or equivalent, to the areas where adhesive is missing. Work the sealer so there is a continuous bead in the gap from the rear of the door beam to the front.
2. Reinstall the front door lower speaker and test to make sure the rattle noise is eliminated. Refer to *Radio Front Side Door Speaker Replacement* in SI.
3. Reposition the water deflector and reinstall the door trim panel. Refer to *Front Side Door Trim Replacement* in SI.

Parts Information

*We believe this source and their products to be reliable. There may be additional manufacturers of such products/materials. General Motors does not endorse, indicate any preference for, or assume any responsibility for the products or material from this firm or for any such items that may be available from other sources.

Part Number	Description
08611	3M Windo-Weld™ Ribbon Sealer

Online URL:

<https://www.corvetteactioncenter.com/tech/knowledgebase/article/2014-2016-corvette-service-bulletin-pi1116a-door-rattle-noise-from-outside-of-vehicle-during-high-radio-volume-or-high-bass-levels-sep-14-2016-1305.html>