

1997 - 1999 Corvette: Service Bulletin: Chime Sounds When Key is Removed from Ignition

Subject: Chime Sounds When Key is Removed from Ignition, Intermittent Operation of Power Door Locks, Keyless Entry, Steering Column Lock or Memory Seats (Inspect/Replace Lock Cylinder Actuator or Lock Cylinder Assembly)

Source: Chevrolet Dealer Technical Service Bulletin

Number: 99-08-49-008

Models:

1997-99 Chevrolet Corvette, Malibu

1997-99 Oldsmobile Cutlass

1998-99 Oldsmobile Intrigue

1999 Oldsmobile Alero

1999 Pontiac Grand Am

This Bulletin is being revised to add additional symptoms and conditions. Please discard Corporate Bulletin Number 83-83-20 (Section 8 - Chassis/Body Electrical)

Condition:

Some customers may comment that the key warning chime continues to sound after the ignition key has been removed from the ignition lock cylinder. They may also comment that the automatic power door locks will not lock the doors when the key is removed from the ignition lock cylinder and the warning chime is sounding.

On Corvette models, some customers may comment that there is an intermittent operation of the passive keyless entry system, the steering column lock, or the retracting feature of the memory power seat option when exiting the vehicle.

Cause:

The actuator, located in the ignition lock cylinder, may be sticking after the key is removed.

Correction:

Remove the ignition lock cylinder for the instrument panel using the following procedures. Once removed from the vehicle, use the "Actuator Type Identification" and "Test Procedure" sections later in this bulletin to determine the correct repair procedure.

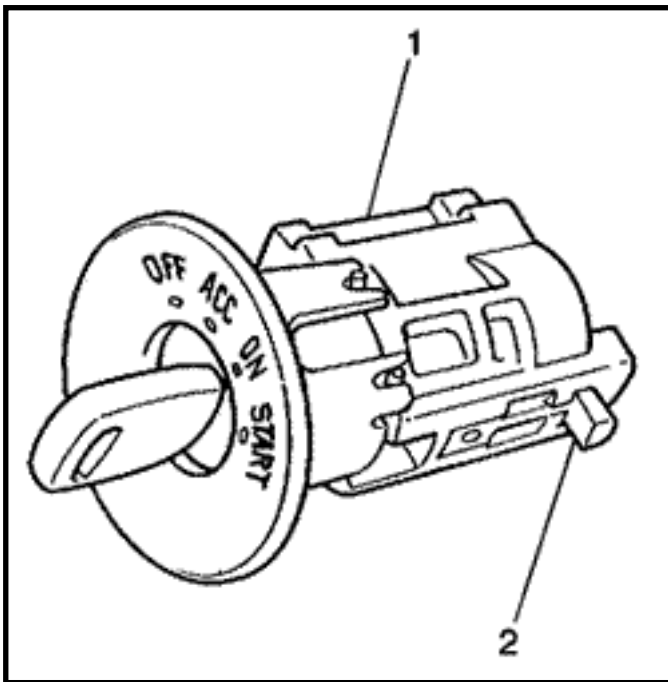

- (1) Installed Position of the Ignition Lock Cylinder
- (2) Location of the Release Plunger (tab) at the 4 o'clock position

Corvette Models -- Lock Cylinder Removal

Use the following steps to remove the lock cylinder:

Caution

When you are performing service on or near the SIR components or the SIR wiring, you must disable the SIR system. Refer to Disabling the SIR

System. Failure to follow the correct procedure could cause air bag deployment, personal injury, or unnecessary SIR system repairs.

1. Disable the SIR system. See the SIR sub-section of Restraints in the Service Manual.
2. Remove the console. See the Instrument Panel & Console sub-section of Body & Accessories in the Service Manual.
3. Remove the instrument panel accessory trim plate. See the Instrument Panel & Console sub-section of Body & Accessories in the Service Manual.
4. Disconnect the electrical connector from the lock cylinder.
5. Insert the key into the lock cylinder and turn to the ON position.
6. Depress and hold the release plunger (tab) on the side of the lock cylinder and pull the lock cylinder from the instrument panel. See Figure 1 for location of the release plunger (tab). See the "Actuator Type Identification" and "Test Procedure" sections later in this bulletin to determine the correct repair procedure.

Corvette Models -- Lock Cylinder Installation

Use the following steps to install the lock cylinder:

1. With the key in the lock cylinder and in the ON position, insert the lock cylinder into the instrument panel until the plunger locks in place.
2. Connect the electrical connector to the lock cylinder.
3. Install the instrument panel accessory trim plate. See the Instrument Panel & Console sub-section of Body & Accessories in the Service Manual.
4. Install the console. See the Instrument Panel & Console sub-section of Body & Accessories in the Service Manual.
5. Enable the SIR system. See the SIR sub-section of Restraints in the Service Manual.

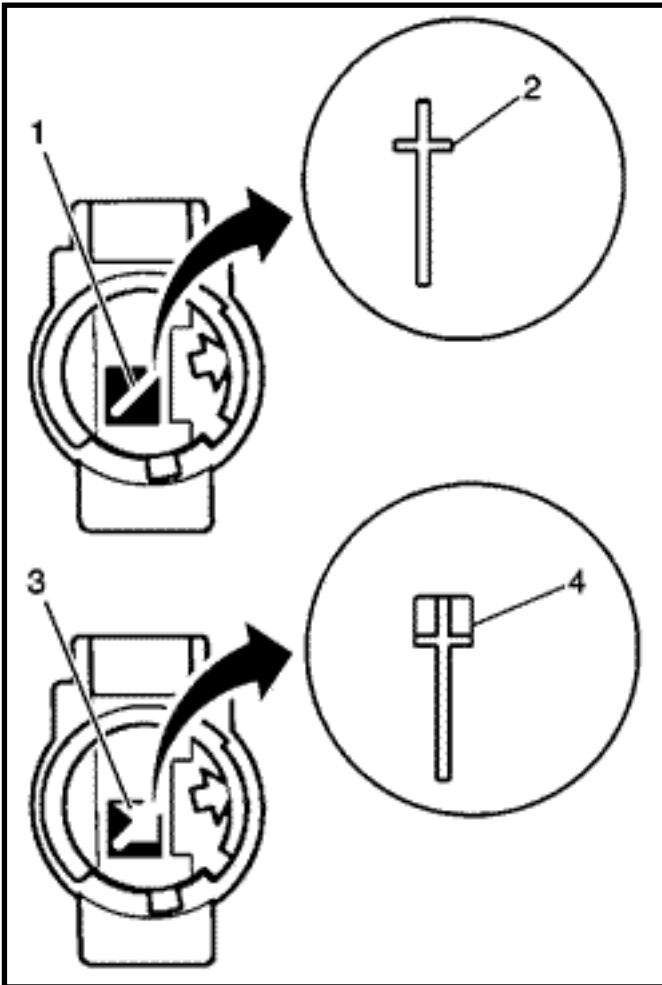

- (1) Early Design Actuator in the Lock Cylinder
- (2) Side View of the Early Design Actuator When Removed from the Lock Cylinder
- (3) New Design Actuator in the Lock Cylinder
- (4) Side View of the New Design Actuator When Removed from the Lock Cylinder

Actuator Type Identification

With the key installed, hold the lock cylinder as shown in Figure 2 to determine what type of actuator is being used. FOLLOW THE APPROPRIATE TEST PROCEDURE FOR THE TYPE OF ACTUATOR BEING USED.

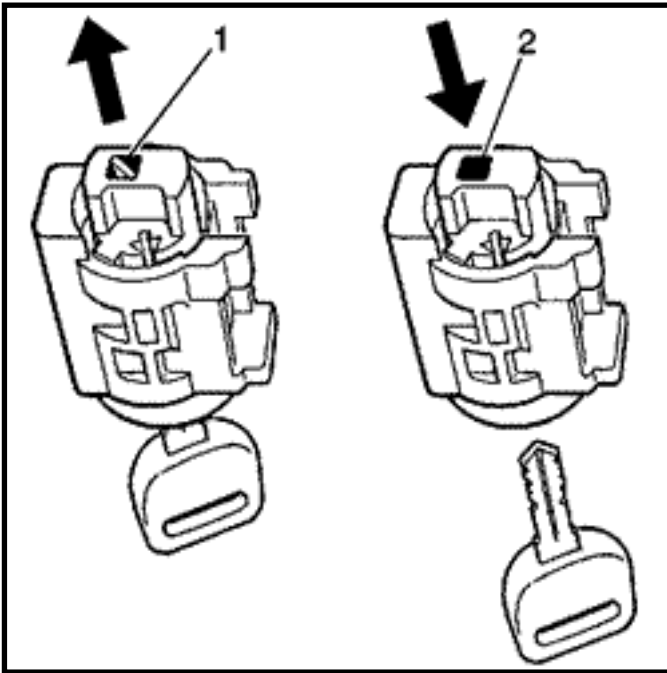

(1) Actuator in the Up Position with the Key INSTALLED in the Lock Cylinder

(2) Actuator in the Down Position with the Key REMOVED from the Lock Cylinder

Test Procedure

Early Design Actuator:

1. With the lock cylinder held vertically as shown in Figure 3, remove the key from the lock. When the key is removed, the actuator should drop down in the lock cylinder approximately 4-5 mm (3/16 in). Repeat this step several times.
2. If the EARLY design actuator in the lock cylinder does NOT drop down, replace the complete lock assembly.
3. If the EARLY design actuator in the lock cylinder DOES drop down, replace the actuator with the new design actuator P/N 12450483.

To replace the actuator, install the key in the lock and grasp the end of the actuator with a pair of small long nose (needle nose) pliers and pull firmly. With the key still in the lock, install the new actuator by aligning the actuator shaft with the opening in the lock cylinder and pushing the actuator into place.

Verify the correct actuator operation by performing Step 1 again.

Important

After installing a new actuator, correct actuator operation must be confirmed.

Test Procedure

New Design Actuator:

1. With the lock cylinder held vertically as shown in Figure 3, remove the key from the lock. When the key is removed, the actuator should drop down in the lock cylinder approximately 4-5 mm (3/16 in). Repeat this step several times.
2. If the NEW design actuator in the lock cylinder does NOT drop down, replace the lock cylinder assembly.

Part Number	Description	Application
12450483	Actuator	All Models Listed Above
12458191	Lock Service Package	All, (Except Corvette)
12458190	Lock Service Package	Corvette Only

GM bulletins are intended for use by professional technicians, NOT a "do-it-yourselfer". They are written to inform these technicians of conditions that may occur on some vehicles, or to provide information that could assist in the proper service of a vehicle. Properly trained technicians have the equipment, tools, safety instructions, and know-how to do a job properly and safely. If a condition is described, DO NOT assume that the bulletin applies to your vehicle, or that your vehicle will have that condition. See your GM dealer for information on whether your vehicle may benefit from the information.

© Copyright General Motors Corporation. All Rights Reserved

Online URL:

<https://www.corvetteactioncenter.com/tech/knowledgebase/article/1997-1999-corvette-service-bulletin-chime-sounds-when-key-is-removed-from-ignition-423.html>