

2001 - 2003 Corvette: Service Manual Update: Revised Wheel Drive Shaft Outer Joint and Seal Replacement and Wheel Drive Shaft Inner Joint and Seal Replacement Procedures

Subject: Revised Wheel Drive Shaft Outer Joint and Seal Replacement and Wheel Drive Shaft Inner Joint and Seal Replacement Procedures

Source: Chevrolet Dealer Technical Service Bulletin

Number: 03-04-95-001 - (01/09/2003)

Models: 2001-2003 Chevrolet Corvette

This bulletin is being issued to revise the Wheel Drive Shaft Outer Joint and Seal Replacement and Wheel Drive Shaft Inner Joint and Seal Replacement procedures in the Rear Wheel Drive Shafts sub-section of the Service Manual. Please replace the current information in the Service Manual with the following information.

The following information has been updated within SI. If you are using a paper version of this Service Manual, please make a reference to this bulletin on the affected page.

Important

Special tool J 46588 is a NEW tool.

Because of a mid-year change in 2001, the large diameter clamp is now a low profile design, instead of the Omega clamp design. The new design clamp requires the use of Special Tool J 46588 to install. The following steps effect 2001 model year vehicles with the second design clamp and all 2002 and future model year vehicles.

The following steps should be used when installing the clamp.

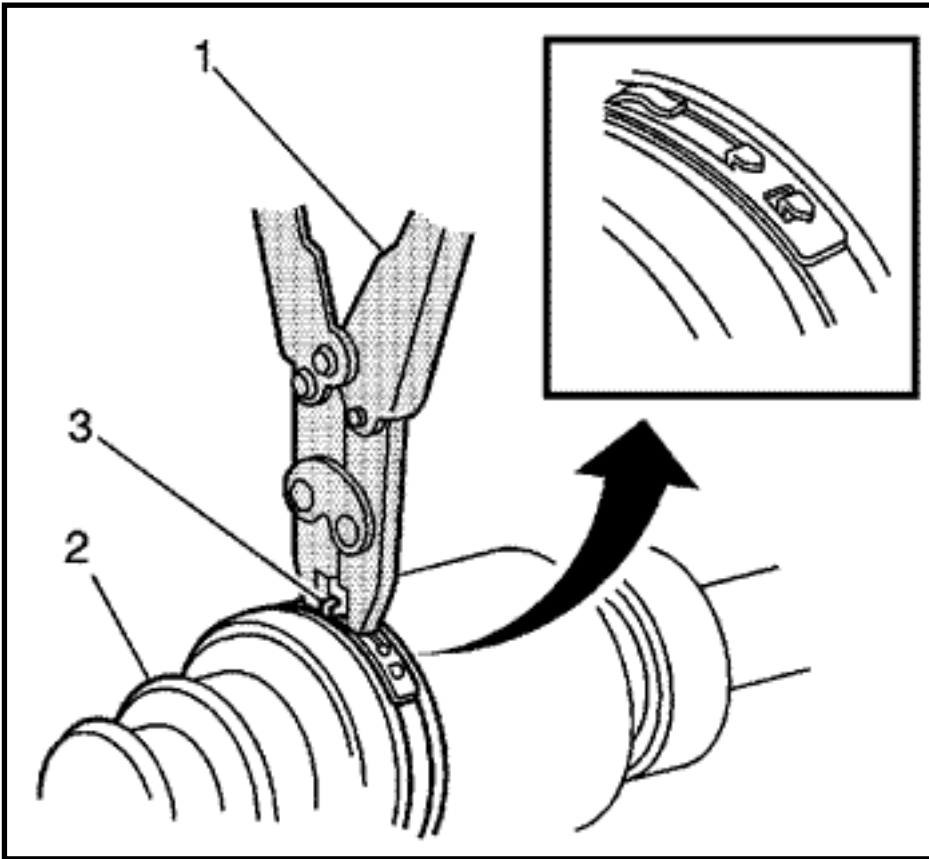

Align the following items while latching:

- The wheel drive shaft inboard seal (2)
- The tripot housing
- The large seal retaining clamp (3)

Using the J 46588 (1), latch the large seal retaining clamp. Ensure that the latching tangs are fully engaged in the large seal clamp band.

GM bulletins are intended for use by professional technicians, NOT a "do-it-yourselfer". They are written to inform these technicians of conditions that may occur on some vehicles, or to provide information that could assist in the proper service of a vehicle. Properly trained technicians have the equipment, tools, safety instructions, and know-how to do a job properly and safely. If a condition is described, DO NOT assume that the bulletin applies to your vehicle, or that your vehicle will have that condition. See your GM dealer for information on whether your vehicle may benefit from the information.

Online URL:

<https://www.corvetteactioncenter.com/tech/knowledgebase/article/2001-2003-corvette-service-manual-update-revised-wheel-drive-shaft-outer-joint-and-seal-replacement-and-wheel-drive-shaft-inner-joint-and-seal-replacement-procedures-446.html>