

1997 - 1998 Corvette: Service Bulletin: Discoloration or Staining of Plenum (Cowl) Air Inlet Screen

Subject: Discoloration or Staining of Plenum (Cowl) Air Inlet Screen

Source: Chevrolet Dealer Technical Service Bulletin

Number: 83-15-11

Models: 1997-1998 Chevrolet Corvette

Condition: SOME CUSTOMERS MAY COMMENT THAT THERE ARE WHITISH SPOTS OR STAINS ON THE PLENUM AIR INLET SCREEN AT THE BASE OF THE WINDSHIELD. THESE SPOTS OR STAINS ARE USUALLY FOUND IN THE AREAS AROUND AND BELOW THE WINDSHIELD WIPER ARMS AND BLADES.

CAUSE:

THIS CONDITION MAY BE CAUSED BY A CHEMICAL RESIDUE USED IN THE MANUFACTURING PROCESS OF THE WINDSHIELD WIPER WASHER NOZZLES. RESIDUE IS WASHED OUT FROM INSIDE THE NOZZLES DURING THE FIRST FEW USAGES OF THE WINDSHIELD WIPER WASHERS.

Correction:

INSTALL NEW AIR INLET SCREEN (P/N 10418245), USING THE PROCEDURES IN THE APPROPRIATE SERVICE MANUAL

PARTS INFORMATION:

10418245 SCREEN - AIR INLET

Figure 1

Figure 1

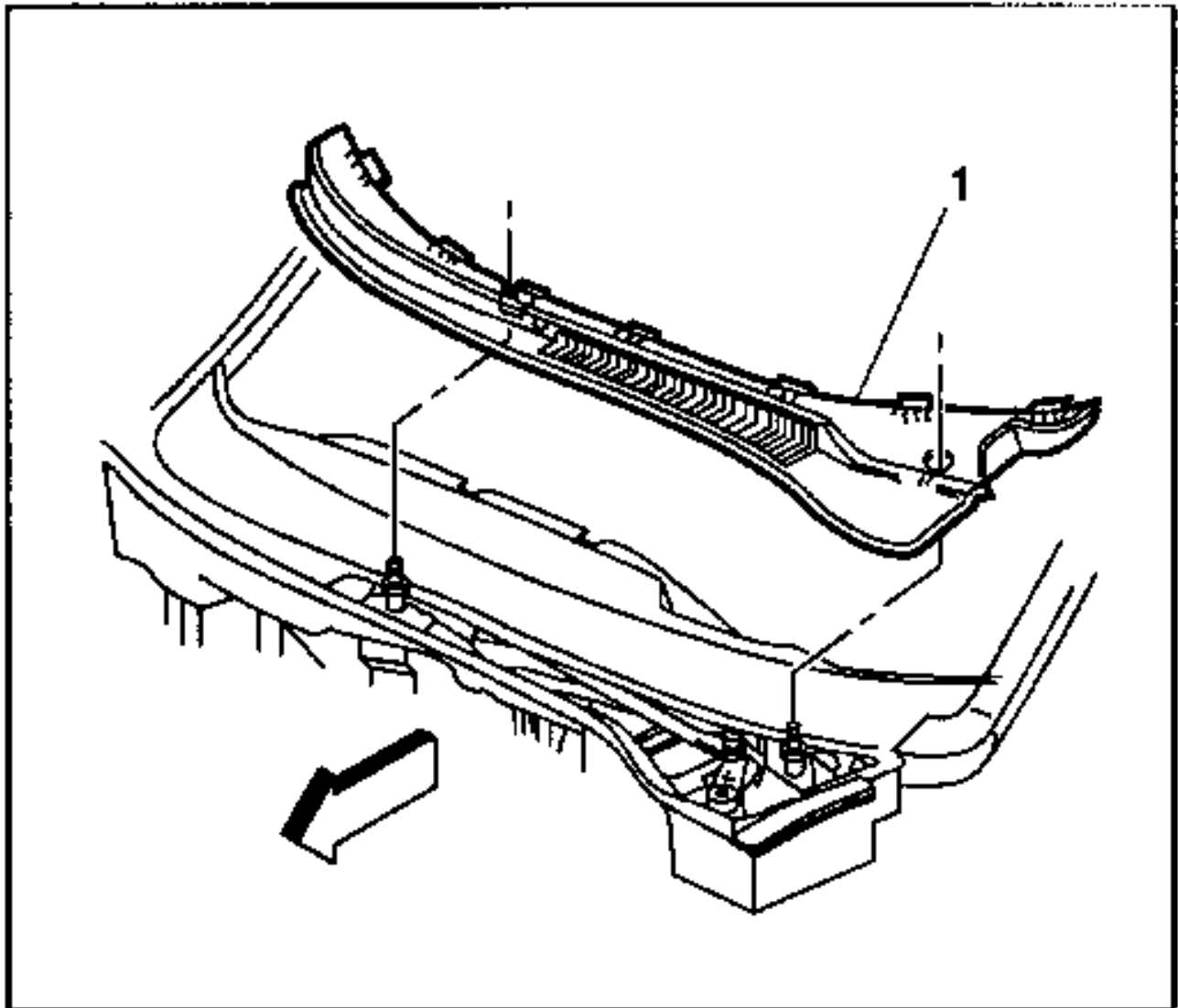

Legend

- 1. Plenum (Cowl) Air Inlet Screen/Grille/Panel

GM bulletins are intended for use by professional technicians, NOT a "do-it-yourselfer". They are written to inform these technicians of conditions that may occur on some vehicles, or to provide information that could assist in the

proper service of a vehicle. Properly trained technicians have the equipment, tools, safety instructions, and know-how to do a job properly and safely. If a condition is described, DO NOT assume that the bulletin applies to your vehicle, or that your vehicle will have that condition. See your GM dealer for information on whether your vehicle may benefit from the information.

COPYRIGHT 1998 GENERAL MOTORS CORPORATION. ALL RIGHTS RESERVED

Online URL:

<https://www.corvetteactioncenter.com/tech/knowledgebase/article/1997-1998-corvette-service-bulletin-discoloration-or-staining-of-plenum-cowl-air-inlet-screen-474.html>