

1991 - 1992 Corvette: Service Bulletin: Starter Inoperative/Clicks/No Start

Subject: Starter Inoperative/Clicks/No Start

Model and Year: 1991-92 Corvette with Automatic Transmission

Source: Chevrolet Service Bulletin

Bulletin Number: 92-322-6D

Condition:

The starter may not operate (no sound), or may click (spins but fails to fully engage the flywheel), resulting in a no-start. This condition may also be intermittent. The condition appears to be similar to a low battery or a defective starter. There will be no codes set in the ECM or CCM, as there would be in a condition caused by the VATS system.

Cause:

The 10 gauge purple wire from the park/neutral switch in the console is rubbing against the shift bracket (see illustration). This causes high resistance in the circuit, resulting in low voltage to the starter.

Correction:

This condition existed from start of production in 1991, to VIN N5107500 in 1992. The plastic in the console was changed to allow for positive routing of the wire harness after the above breakpoint.

To correct this condition, perform the following steps:

1. Disconnect negative battery cable.
2. Remove console trim plate as shown in the 1992 Y Car Service Manual, page 8C-11.
3. Check the wire harness in the area shown in the illustration for signs of rubbing. Correct as necessary.

NOTE: If no rub area can be found in a 1991 vehicle, a similar condition with a different cause was covered earlier in Dealer Service Bulletin 91-337-6D.

4. Reroute the harness to the right of the bracket, about 50 mm (2 inches) over, and under the plastic portion of the console. Secure as needed to insure that the harness cannot contact the bracket

5. Reinstall the console trim plate.

6. Connect the negative battery cable, and insure that the starter works properly

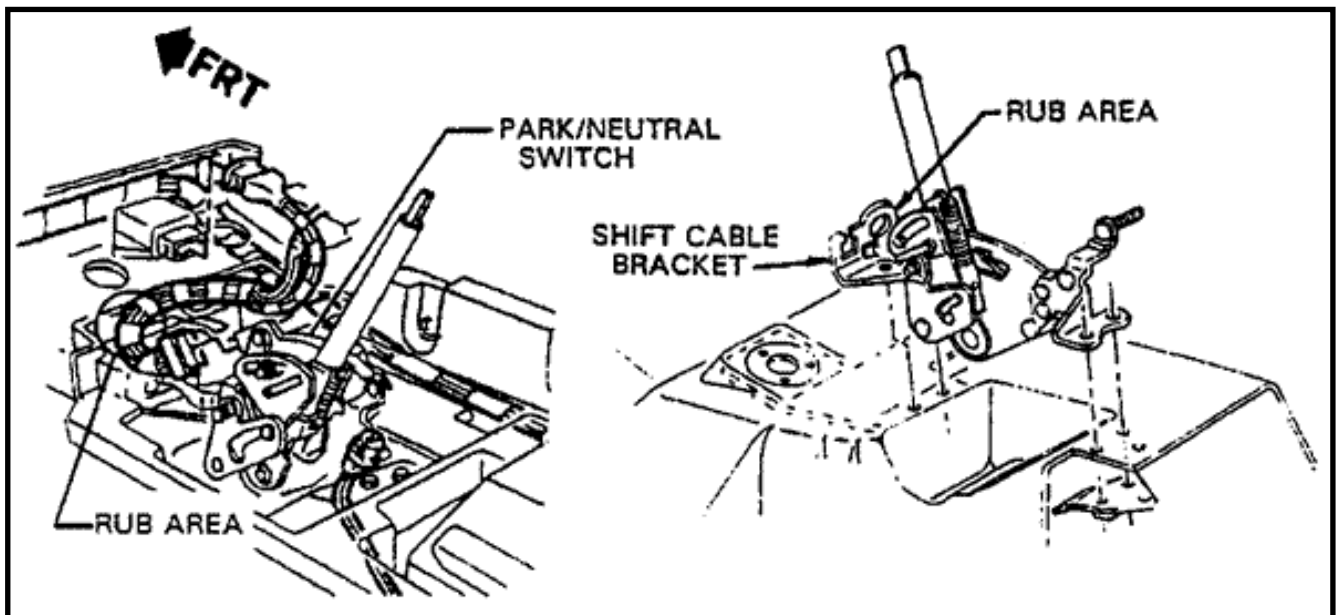

General Motors bulletins are intended for use by professional technicians, not a "do-it-yourselfer". They are written to inform those technicians of conditions that may occur on some vehicles, or to provide information that could assist in the proper service of a vehicle. Properly trained technicians have the equipment, tools, safety instructions and know-how to do a job properly and safely. If a condition is described, do not assume that the bulletin applies to your vehicle, or that your vehicle will have that condition. See a General Motors dealer servicing your brand of General Motors vehicle for information on whether your vehicle may benefit from the information.

© Copyright General Motors Corporation. All Rights Reserved

Online URL:

<https://www.corvetteactioncenter.com/tech/knowledgebase/article/1991-1992-corvette-service-bulletin-starter-inoperative-clicks-no-start-559.html>