

# 1984 Corvette: Recall: Rear Axle Differential Cross Shaft Retention

**Subject:** REAR AXLE DIFFERENTIAL CROSS SHAFT RETENTION

**Model and Year:** 1984 CHEVROLET CORVETTE MODELS

**Source:** Chevrolet Campaign

**Bulletin Number:** 84-C-25 - (09/20/1985)

## **TO: ALL CHEVROLET DEALERS**

The National Traffic and Motor Vehicle Safety Act, as amended, provides that each vehicle which is subject to a recall campaign of this type must be adequately repaired within a reasonable time after the owner has tendered it for repair. A failure to adequately repair within 60 days after tender of a vehicle is prima facie evidence of failure to repair within a reasonable time.

If the condition is not adequately repaired within a reasonable time, the owners may be entitled to an identical or reasonably equivalent vehicle at no charge or to a refund of the purchase price less a reasonable allowance for depreciation.

To avoid having to provide these burdensome solutions, every effort must be made to promptly schedule an appointment with each owner and to repair their vehicle as soon as possible. As you will see in reading the attached copy of the letter which is being sent to owners, the owners are being instructed to contact the nearest Chevrolet Zone Office if their dealer does not remedy the condition within five days of the mutually agreed upon service date. If the condition is not remedied within a reasonable time, they are instructed on how to contact the National Highway Traffic Safety Administration.

## **DEFECT INVOLVED**

General Motors has determined that a defect which relates to motor Vehicle Safety exists in some 1984 Chevrolet Corvette models. Some 1984 Corvettes may experience lose of the wire snap rings that retain the differential cross shaft in its proper position in the rear axle differential case assembly. This may result in the differential cross shaft protruding out of the differential case assembly and contacting the carrier or pinion teeth, possibly locking up the rear wheel and resulting in a vehicle crash without prior warning.

To prevent the possibility of this condition occurring a rear axle differential cross shaft retention kit will be installed on all involved vehicles.

## **VEHICLES INVOLVED**

The involved vehicles are identified within the following vehicle parameters:

PLANT FROM THROUGH

-----

Bowling Green E5100001 E5148659

Involved vehicles have been identified by Vehicle Identification Number Computer Listings. Computer listings contain the complete Vehicle Identification Number, owner name and address data, and are furnished to the involved dealers with the campaign bulletin. Owner name and address data furnished will enable dealers to follow-up with owners involved in this campaign.

These listings may contain owner names and addresses obtained from State Motor Vehicle Registration Records. The use of such motor vehicle registration data for any other purpose is a violation of law in several states. Accordingly, you are urged to limit the use of this listing to the follow-up necessary to complete this campaign. Any dealer not receiving a computer listing with the campaign bulletin was not shipped any involved vehicles.

## **OWNER NOTIFICATION**

Owners will be notified of this campaign on their vehicles by Chevrolet Motor Division (see copy of Owner Letter included with this bulletin).

## **DEALER CAMPAIGN RESPONSIBILITY**

Dealers are to service all vehicles subject to this campaign at no charge to owners, regardless of mileage, age of vehicle, or ownership, from this time forward.

Whenever a vehicle subject to this campaign is taken into your new or used vehicle inventory, or it is in your dealership for service in the future, you should take the steps necessary to be sure the campaign correction has been made before reselling or releasing the vehicle.

## **DEALER CAMPAIGN RESPONSIBILITY**

Owners of vehicles recently sold from your new vehicle inventory are to be contacted by the dealer, and arrangements made to make the required modification according to instructions contained in this bulletin.

## **SERVICE PROCEDURE**

1. Remove differential carrier and cover assembly from vehicle following appropriate procedure noted in 1985 Corvette Shop Manual.
2. With differential carrier and cover assembly positioned on a suitable working surface, remove six (6) bolts securing cover to differential carrier, remove cover and drain lube.
3. Remove snap rings retaining differential output yokes and slide yokes out of the assembly.

TAG YOKES AND SNAP RINGS TO INDICATE WHICH SIDE THEY WERE REMOVED FROM TO INSURE PROPER REASSEMBLY.

4. Remove differential cross shaft retaining clips and discard.

IF ONE OR BOTH RETAINING CLIPS ARE NOT PRESENT ON CROSS SHAFT, INSPECT DIFFERENTIAL CARRIER FOR MISSING CLIPS TO INSURE THEIR REMOVAL PRIOR TO REASSEMBLY.

5. Rotate case assembly to position illustrated in Figure 1. With appropriate size drift and small mallet, lightly tap on cross shaft to determine if movement of shaft can be achieved.

EXCESSIVE IMPACTING OF CROSS SHAFT CAN RESULT IN DAMAGING OF DIFFERENTIAL SIDE BEARINGS.

6. Based on determination made in performing previous step, proceed to remove existing cross shaft and install new cross shaft by one of the following methods:

a. Loose Cross Shaft - (Movement can be achieved with light tapping).

Tap cross shaft inboard approximately 1 1/4 inches and rotate case 180 DEG. Utilizing vise grips and a back and forth motion, remove shaft. Install new cross shaft insuring detents in the shaft are positioned properly to accept spheres (balls) to be installed, between shaft and output yokes as illustrated in Figure 2.

b. Tight Cross Shaft - (No movement can be achieved with light tapping).

Remove case assembly from carrier following appropriate procedure in 1985 Corvette Shop Manual. Press existing cross shaft out of case and install new cross shaft insuring detents in the shaft are positioned properly to accept spheres (balls) to be installed between shaft and output yokes as illustrated in

Figure 2. Reinstall case assembly following appropriate 1985 Shop Manual procedure.

7. Install new differential cross shaft retaining clips and insure they are properly seated.

8. Clean differential output yokes of any oil and dirt. Place a small amount of standard wheel bearing grease on the ends of the output yokes at the inboard (spline end) center drill hole.

9. Place sphere (balls) in the center drill holes of the output yokes. Install output yokes, insuring spheres (balls) will be positioned properly in the detents of the differential cross shaft.

10. Install differential output yoke snap rings and insure they are properly seated. Visually inspect that spheres (balls) are in proper position after snap ring installation and seating.

**TAPPING INBOARD ON OUTPUT YOKES MAY BE REQUIRED TO INSURE SNAP RINGS CAN BE PROPERLY SEATED IN OUTPUT YOKE GROOVES.**

11. Clean mating surfaces of cover and differential carrier insuring surfaces are free of any oil film and/or foreign material. Apply a continuous 1/4" bead of RTV to the mating surface of the carrier.

**RTV BEAD MUST BE POSITIONED INBOARD AROUND THE BOLT HOLES TO INSURE PROPER SEALING OF THE ASSEMBLY.**

12. Position cover on carrier and install the six (6) attaching bolts. Torque bolts to 27-34 Nm (20-25 Ft. Lbs.) while RTV is still wet.

13. Install differential carrier and cover assembly in vehicle following appropriate procedure noted in 1985 Corvette Shop Manual.

14. Install Campaign identification label.

**PARTS INFORMATION**

Parts required to complete this modification are to be obtained from General Motors Warehousing and Distribution Division (GMWDD). To ensure that these parts will be obtained as soon as possible they should be ordered from GMWDD on a C. I.O. order with no special instruction code, but an an advise code (2).

Quantity Part Number Description Per Vehicle

-----

14105604 Rear Axle Differential 1 Cross Shaft Retention Kit

1052358 Friction Modifier (4 oz.) 1

1052271 Lubricant (24 oz.) 2

**CLAIM INFORMATION**

Submit a Product Campaign Claim with the information indicated below:

Parts Failed. \*\*Parts Failure Labor Labor \*Other Count Part No. Allowance  
Code Operation Hours Hours

-----

4 14105604 00 V2910 3.5 .1

DESCRIPTION: Install Rear Axle Differential Cross Shaft Retention Kit without case removal according to the instructions outlined in this bulletin.

Parts Failed \*\*Parts Failure Labor Labor \*Other Count Part No. Allowance  
Code Operation Hours Hours

-----

4 14105604 00 V2911 3.9 .1

DESCRIPTION: Install Rear Axle Differential Cross Shaft Retention Kit with case removed according to the instructions outlined in this bulletin.

\*Campaign Administrative Allowance.

\*\*The Parts Allowance should be the sum total of the current GMWDD Dealer Net plus 30% of all parts required for the repair.

Dealers will automatically receive the correct labor allowance based on the labor operation performed.

Refer to the Chevrolet Claims Processing Manual for details on Product Campaign Claim submission.

### **CAMPAIGN IDENTIFICATION LABEL**

Each vehicle modified in accordance with the instructions outlined in this Product Campaign Bulletin will require a "Campaign Identification Label." Each label provides a space to include the five digit dealer code of the dealer performing the campaign services. This information may be inserted with a typewriter or ballpoint pen.

Each "Campaign Identification Label" is to be located on the radiator core support in an area which will be visible when the vehicle is brought in for periodic servicing by the owner.

Apply "Campaign Identification Label" only on a clean dry surface.

## **ADMINISTRATIVE PROCEDURE**

Refer to the current Chevrolet service policies and procedures manual and claims processing manual for campaign handling and administrative procedures.

Dear Chevrolet Owner:

This notice is sent to you in accordance with the requirements of the National Traffic and Motor Vehicle Safety Act.

General Motors has determined that a defect which relates to Motor Vehicle Safety exists in some 1984 Chevrolet Corvette models. Some 1984 Corvettes may experience loss of the wire snap rings that retain the differential cross shaft in its proper position in the rear axle differential case assembly. This may result in the differential cross shaft protruding out of the differential case assembly and contacting the carrier or pinion teeth, possibly locking up the rear wheels and resulting in a vehicle crash without prior warning.

To prevent this from occurring on your vehicle, please contact your Chevrolet Dealer to arrange a service date. The dealer will install a rear axle differential cross shaft retention kit. This service will be completed for you at no charge.

Instructions for making this correction have been sent to your Chevrolet Dealer. It is estimated that parts will be available on October 1, 1985. The labor time necessary to install the rear axle differential cross shaft retention kit varies between 3 1/2 and 4 hours. Please ask your dealer if you wish to know how much additional time will be needed to process your vehicle.

Your Chevrolet Dealer is best equipped to obtain parts and provide service to ensure your vehicle is corrected as promptly as possible. However, if you take your vehicle to your dealer on the agreed service date, and they do not remedy this condition on that date or within five days, we recommend you contact the nearest Chevrolet Zone Office, either in person or by telephone. The Zone



Office will assist you and the dealer in getting your vehicle corrected. The locations and telephone numbers of the Zone office are listed in your Owner's Manual.

After contacting your dealer and the Zone Office, if you are still not satisfied that we have done our best to remedy this condition without charge and within a reasonable time, you may wish to write the Administrator, National Highway traffic Safety Administration, 400 Seventh St., S.W. Washington, D.C. 20590 or call 800-424-9393 (Washington, D.C. residents use 426-0123).

The enclosed owner reply card identifies your vehicle. Presentation of this card to your dealer will assist in making the necessary correction in the shortest possible time. If you have sold or traded your vehicle. please let us know by completing the postage paid owner reply card and returning it to us.

We are sorry to cause you this inconvenience; however, we have taken this action in the interest of your safety and continued satisfaction with our products.

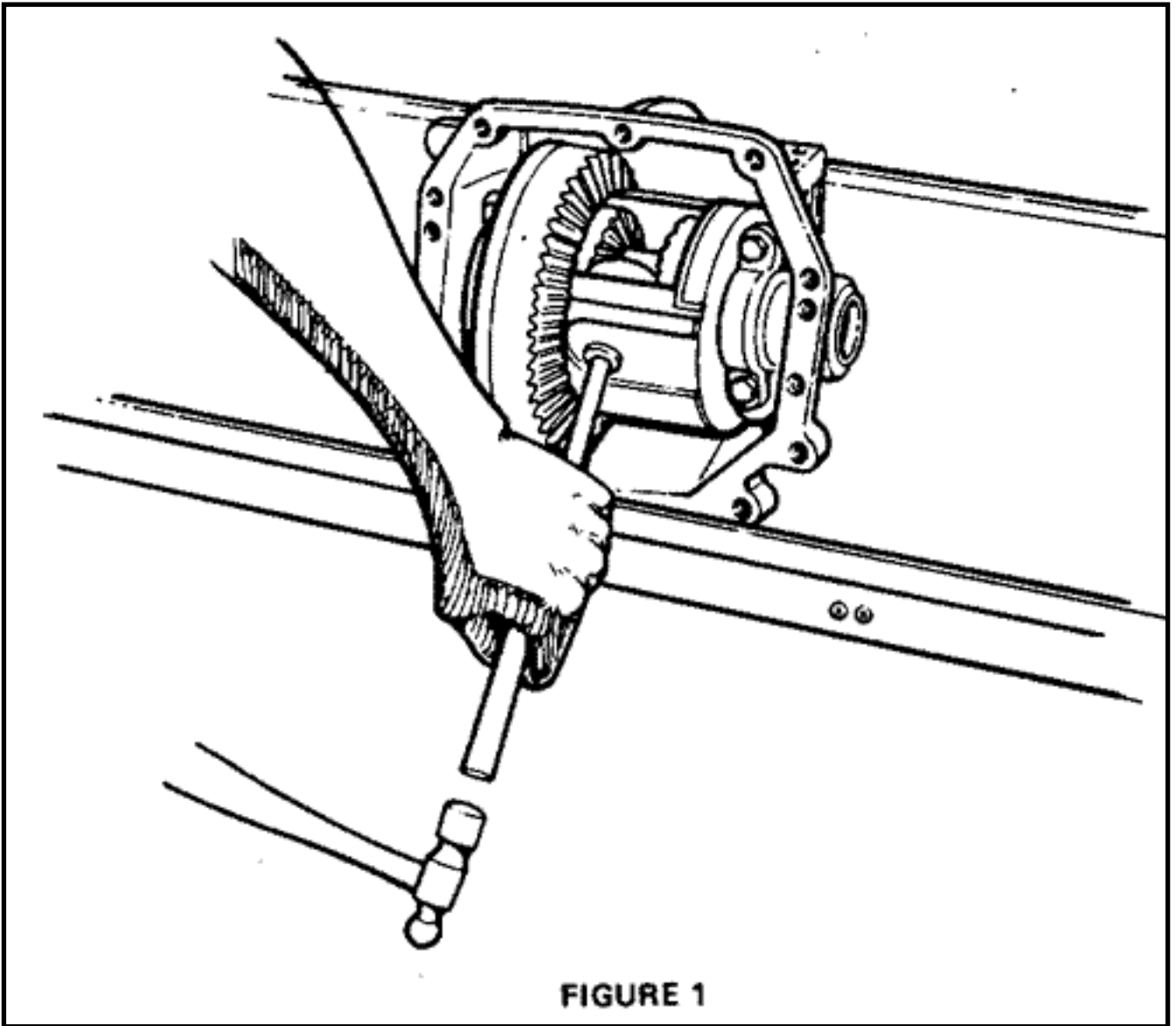
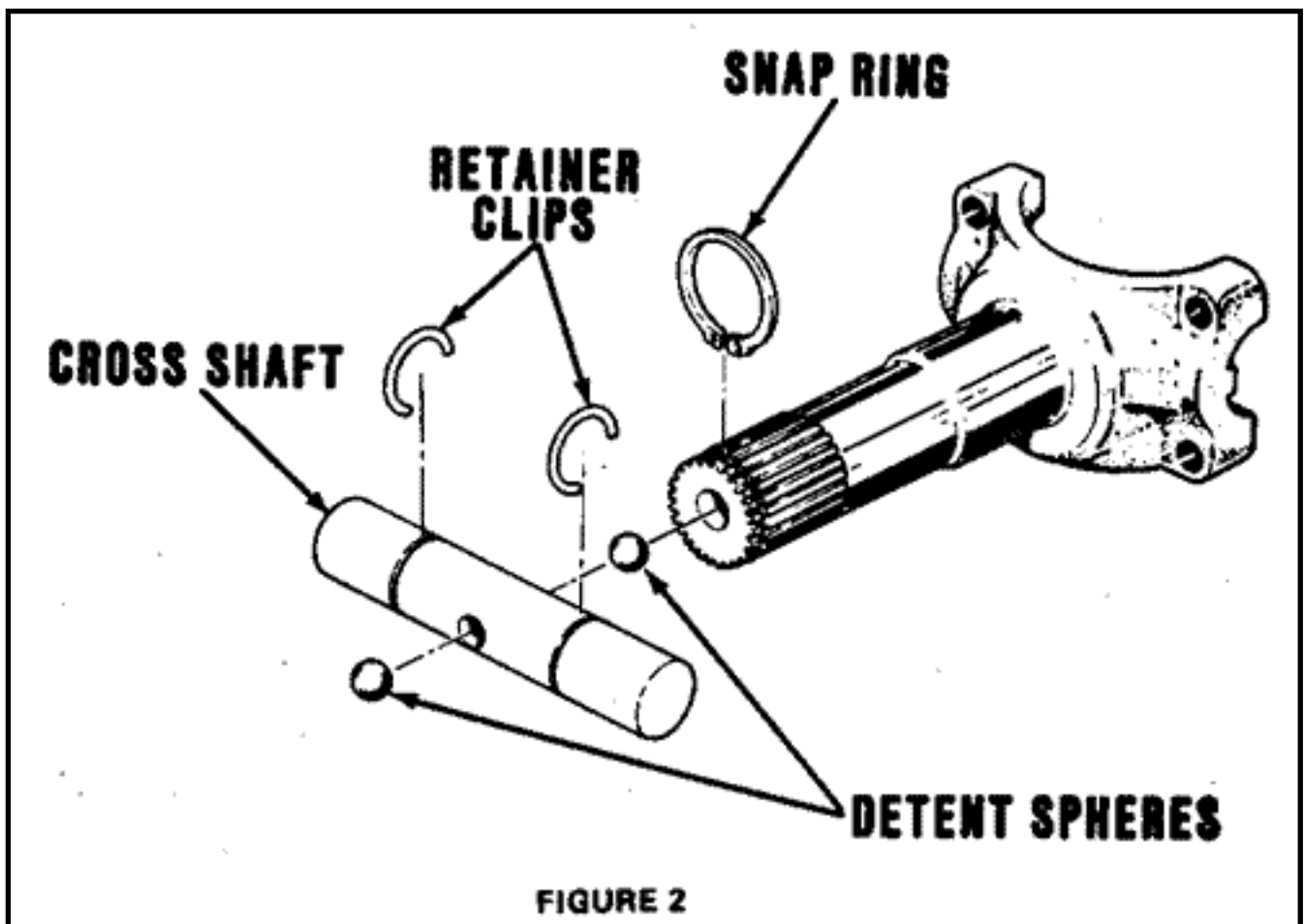

FIGURE 1



**FIGURE 2**

General Motors bulletins are intended for use by professional technicians, not a "do-it-yourselfer". They are written to inform those technicians of conditions that may occur on some vehicles, or to provide information that could assist in the proper service of a vehicle. Properly trained technicians have the equipment, tools, safety instructions and know-how to do a job properly and safely. If a condition is described, do not assume that the bulletin applies to your vehicle, or that your vehicle will have that condition. See a General Motors dealer servicing your brand of General Motors vehicle for information on whether your vehicle may benefit from the information.

**© Copyright General Motors Corporation. All Rights Reserved**

Online URL:

<https://www.corvetteactioncenter.com/tech/knowledgebase/article/1984-corvette-recall-rear-axle-differential-cross-shaft-retention-628.html>

