

# 1992 Corvette: Service Bulletin: Hood Latch Striker Bolt

**Subject:** HOOD LATCH STRIKER BOLT (USE PAST MODEL SERVICE PARTS)

**Model and Year:** 1992 Corvettes, Prior to VIN Breakpoint N5100919

**Source:** Chevrolet Service Bulletin

**Bulletin Number:** 92-43-10 - (11/07/1991)

**Condition:** Early model 1992 Corvettes (prior to VIN breakpoint above) were built with unique hood latch striker bolts and pop up springs.

**NOTE:** These type parts are not available from GMSPO and, if service is required, should be replaced with previous model (1989-91) type parts.

**Correction:** Parts Required- 14043052 - Spring 14043053 - Retainer 14084413 - Bolt, Hd. Pri. Lch. 11508269 - Bolt, M8 X 1.25 X 30

Parts are currently available from GMSPO.

1. Raise hood to full open position. 2. Remove pop up spring and attaching bolt from bracket and discard (see View A). 3. Install new attaching bolt in position, tighten and torque to 27 N.m (20 lbs. ft.). 4. Loosen the locking nut on the striker latch bolt, remove bolt and nut from hood bracket, disassemble nut from bolt and save the nut for use on the new striker bolt. **DISCARD THE ORIGINAL STRIKER BOLT.** 5. Preassemble the new bolt, retainer, spring and original lock nut (see View B).

**NOTE:** The nut has a cavity on one side to act as spring seat.

6. Install the new striker bolt assembly to the bracket on hood, set initial

height as indicated on the illustration and tighten the locking nut. 7. Remove the outer attaching bolt for the spring seat (View C), loosen the inner attaching bolt and remove and discard the spring seat and outer attaching bolt. 8. Tighten the inner attaching bolt and torque to 25 N.m (18 lbs. ft.), see View C, inside View. 9. Carefully lower hood, check for latching and flushness conditions and adjust as required.

Labor Operation Number: B1560

Use applicable labor time guide for labor hours.

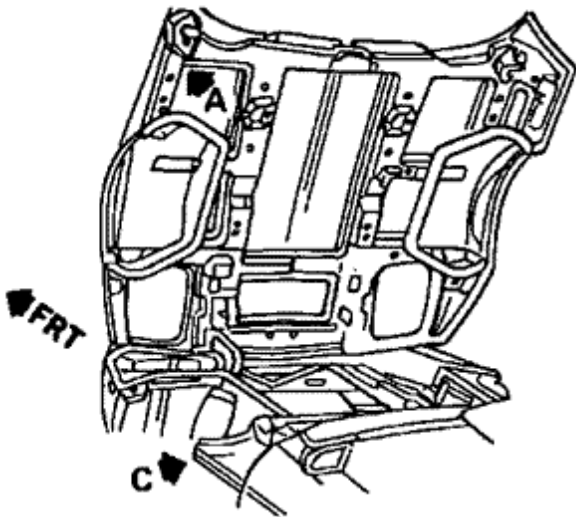

UNDERSIDE OF HOOD

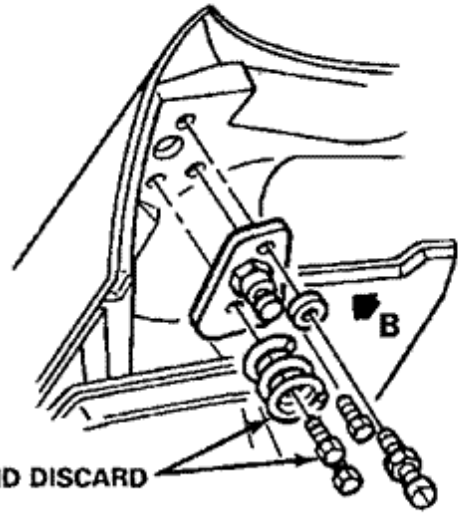

REMOVE AND DISCARD

VIEW A

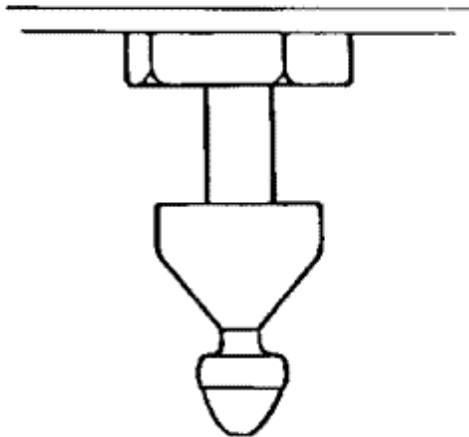

VIEW B — PRODUCTION

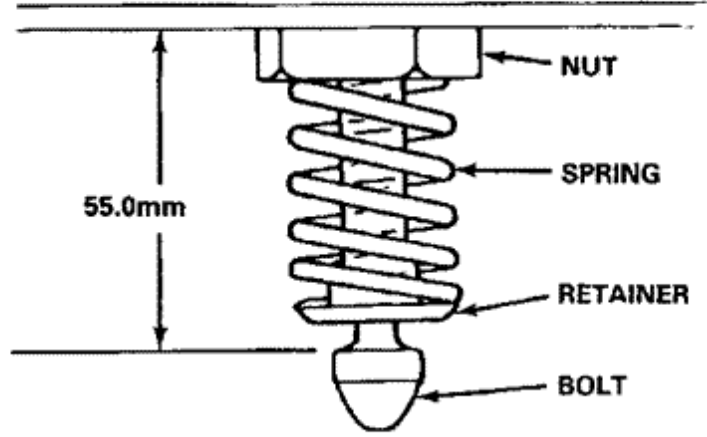

VIEW B — SERVICE

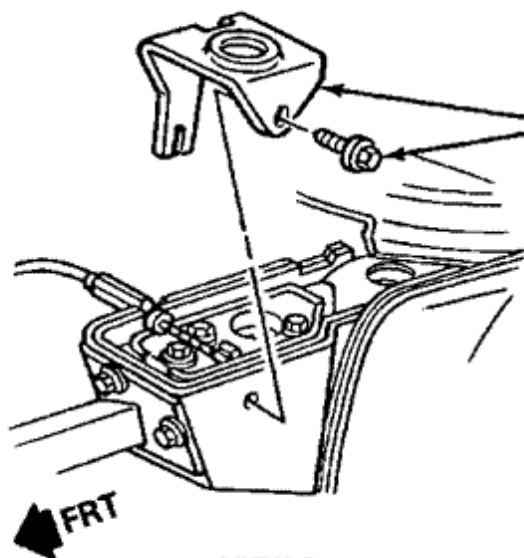

VIEW C  
OUTSIDE VIEW

REMOVE AND DISCARD

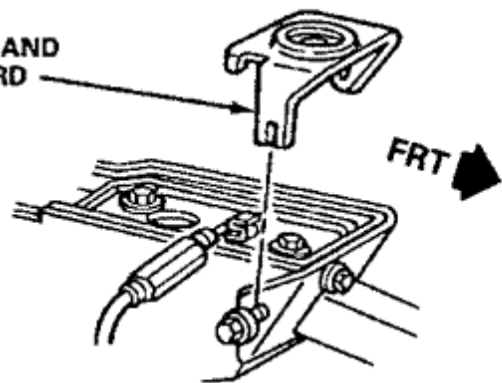

VIEW C  
INSIDE VIEW

General Motors bulletins are intended for use by professional technicians, not a "do-it-yourselfer". They are written to inform those technicians of conditions that may occur on some vehicles, or to provide information that could assist in the proper service of a vehicle. Properly trained technicians have the equipment, tools, safety instructions and know-how to do a job properly and safely. If a condition is described, do not assume that the bulletin applies to your vehicle, or that your vehicle will have that condition. See a General Motors dealer servicing your brand of General Motors vehicle for information on whether your vehicle may benefit from the information.

**© Copyright General Motors Corporation. All Rights Reserved**

Online URL:

<https://www.corvetteactioncenter.com/tech/knowledgebase/article/1992-corvette-service-bulletin-hood-latch-striker-bolt-649.html>