

1982 Corvette: Service News: Fuel injection Diagnosis Chart Revision

1982 Corvette production ended on October 12, 1982. The information below was issued in the Spring of 1983 and is not in any of the original shop manuals for the 1982 Corvette model year.

Subject: Fuel injection Diagnosis Chart Revision

Model and Year: 1982 Citation / Celebrity, Camaro and Corvette Shop Manuals

Source: Chevrolet Service News

Page Number: March-April 1983 - Volume 55, Issue Number 2

Date: NA

The chart in Figure 2 has been revised and is being provided to update the following 1982 shop manuals:

- ST-365-82 -- Citation/Celebrity, Pag. 6E2-44
- ST-368-82 -- Camaro, Pg. 6E2-57
- ST-364-82 -- Corvette, Pg. 6E-48

1982-1983

CODE 44

FUEL INJECTION
LEAN EXHAUST INDICATION

A CODE 33 OR 34 MAY CAUSE A CODE 44. THEREFORE, IF EITHER OF THESE CODES IS PRESENT, SEE THAT CODE CHART FIRST.

- * ● GROUND DIAGNOSTIC TERMINAL.
- RUN WARM ENGINE AT 2000 TO 2200 RPM FOR 1 MINUTE AND NOTE "CHECK ENGINE" LIGHT.
- RUN ENGINE AT 1200 TO 1400 RPM FOR ONE MINUTE AND NOTE "CHECK ENGINE" LIGHT.

FLASHING "CLOSED LOOP" AT BOTH RPMs

TROUBLE IS INTERMITTENT, SEE CHART 1

LIGHT STAYING "OFF" MORE THAN "ON" OR FLASHING "OPEN LOOP" AT EITHER RPM

- * ● IGNITION "OFF".
- DIAGNOSTIC TERMINAL GROUNDED.
- DISCONNECT OXYGEN SENSOR.
- START ENGINE AND IMMEDIATELY NOTE "CHECK ENGINE" LIGHT.

* "CHECK ENGINE" LIGHT WENT OFF FOR AT LEAST 15 SECONDS.

CHECK SIGNAL CKT 412 FOR OPEN OR SHORT TO GROUND

CKT 412 OK

FAULTY ECM CONNECTOR OR ECM

"CHECK ENGINE" LIGHT FLASHING OPEN LOOP.

- * ● CHECK FOR OPEN GROUND CIRCUIT 413. IF NOT OPEN CHECK:
 - FOR GROUND IN WIRE FROM CONNECTOR TO SENSOR.
 - FOR INTAKE AIR LEAKS, INCLUDING AIR MANAGEMENT.
 - FOR IMBALANCE OF TBI UNITS ON 5.0L AND 5.7L.
 - EGR. SEE SERVICE MANUAL SECTION 6E FOR TVS CONTROLLED OR CHART 8 FOR ECM CONTROLLED.
 - FUEL PRESSURE. SHOULD BE 9-13 PSI.
 - FOR EXHAUST MANIFOLD LEAKS AHEAD OF SENSOR.

ALL CHECKS OK

FAULTY OXYGEN SENSOR

CLEAR CODES AND CONFIRM "CLOSED LOOP" OPERATION AND NO "CHECK ENGINE" LIGHT.

FIELD SERVICE MODE:

ENGINE RUNNING, DIAGNOSTIC TERMINAL GROUNDED.

OPEN-LOOP: "CHECK ENGINE" LIGHT FLASHES AT A RATE OF 2 TIMES PER SECOND.

CLOSED LOOP: "CHECK ENGINE" LIGHT FLASHES AT A RATE OF 1 TIME PER SECOND.

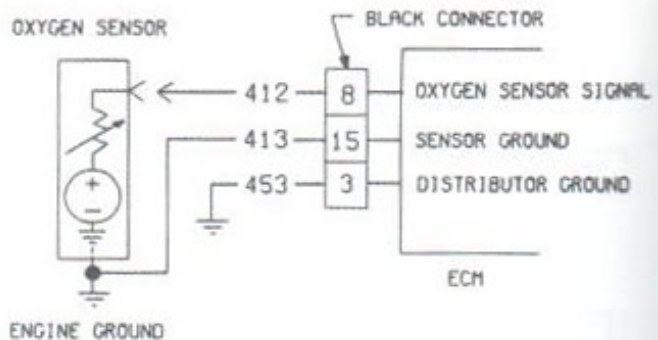

*REVISED 12-9-82 Z

Fig. 2 — Lean Exhaust Indication

Online URL:

<https://www.corvetteactioncenter.com/tech/knowledgebase/article/1982-corvette-service-news-fuel-injection-diagnosis-chart-revision-844.html>