

1984 Corvette: Service Bulletin: Broken Window Regulator Tapes

Subject: Broken Window Regulator Tapes

Model and Year: 1984 Corvette

Source: Chevrolet Dealer Service Bulletin

Bulletin No: 84-3

Section: 10 (I)

Date: Oct., 1983

TO: ALL CHEVROLET DEALERS

Some power windows may not be closing due to broken drive tapes.

Beginning with VIN E5111879, Bowling Green has changed to regulators with low torque motors and new flex rack design.

Whenever a vehicle requires service of door components, inspect for interference between the forward upper attaching screw and the upper end of the tape drive. If interference exists, one of the following options should be performed:

1. Add a washer (P/N 14038397), or equivalent, under the upper forward attaching screw (See Illustration).
2. Remove the forward attaching screw (P/N 11503800) and grind approximately 3mm from the threaded end.

This is to prevent contact between the bottom of the screw and the upper end of the tape drive. If this contact exists, excessive stress is created in the tape and could cause a failure.

Part numbers on the regulators did not change. To identify the revised regulators, check the electric motor part number.

- Old Hi Torque - P/N 22039929

- New Low Torque - P/N 22048553

A limited number of service regulators with new flex racks and low torque motors have been available since July 18, 1983. By the end of August, an adequate supply of regulators should be available.

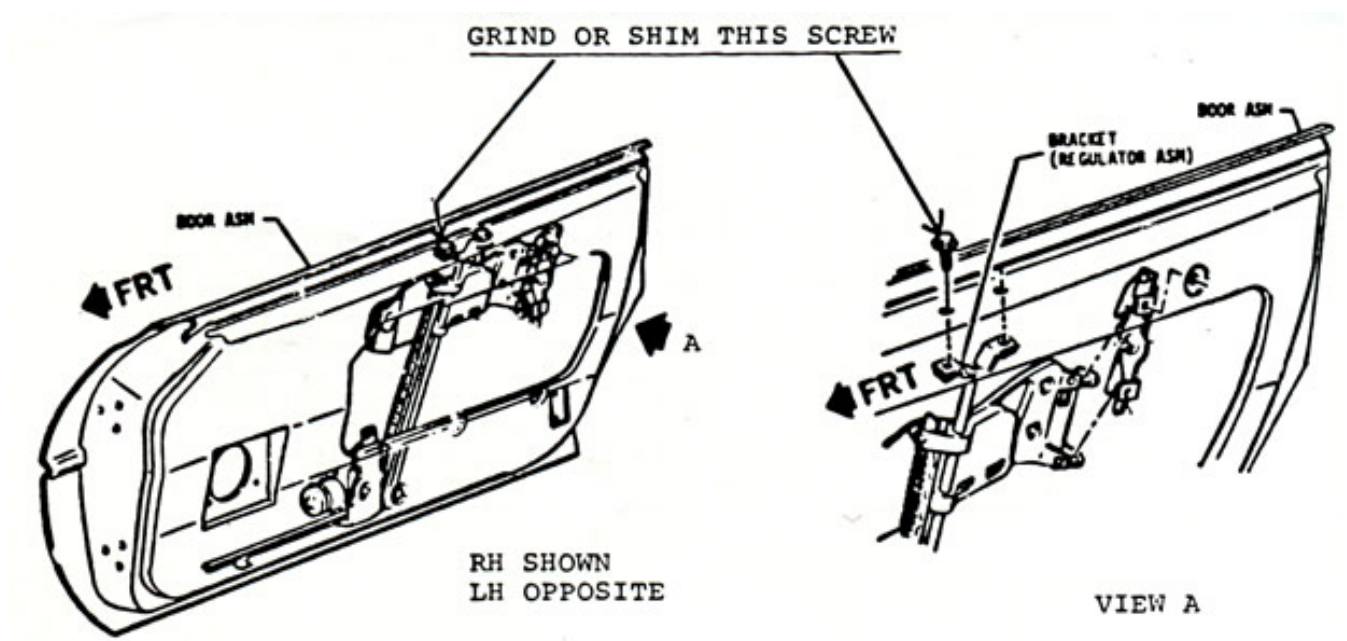

Online URL:

<https://www.corvetteactioncenter.com/tech/knowledgebase/article/1984-corvette-service-bulletin-broken-window-regulator-tapes-983.html>